

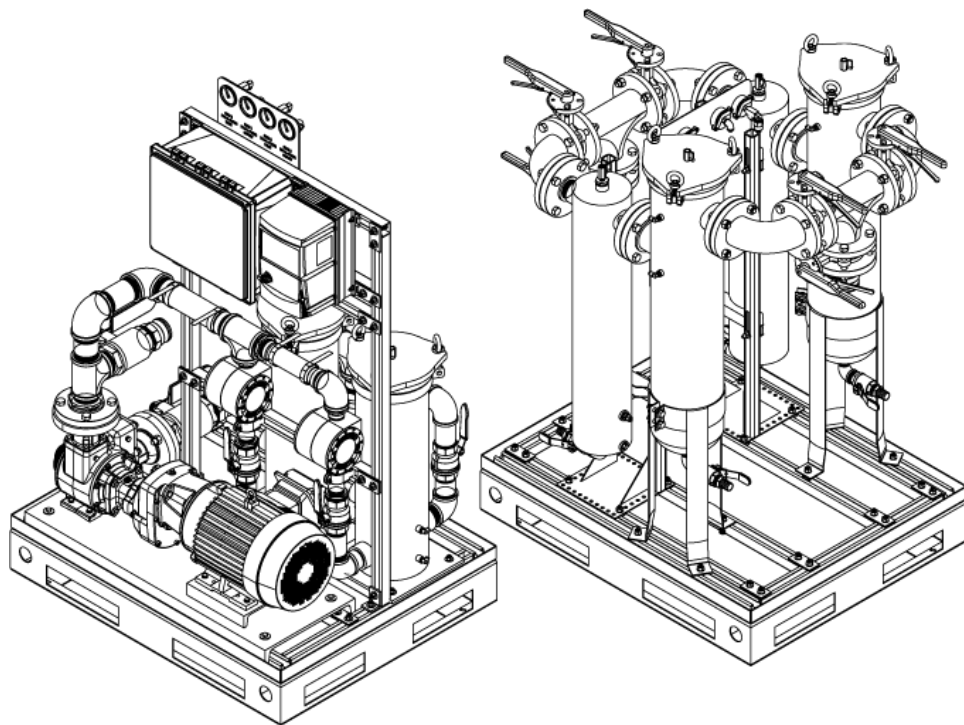

# **MTC HC-150 Instruction, Operating, & Maintenance Manual**

**HIGH CAPACITY MOBILE FUEL POLISHING SYSTEM**

*REV0303HC150010320*



# Table of Contents

<b>Table of Contents</b> .....	<b>2</b>
<b>General Overview</b> .....	<b>3</b>
MTC HC-150 Specifications.....	3
<b>System Components</b> .....	<b>4</b>
Control and Safety Devices .....	4
Pump/Motor .....	4
Primary Filters.....	4
Mechanical Water Separators.....	4
Fuel Conditioners.....	4
Secondary Filters .....	4
Plumbing.....	4
<b>System Operation</b> .....	<b>5</b>
Setup Procedures .....	5
Pump Operation.....	5
Phase 1 .....	6
Phase 2.....	6
Phase 3.....	7
Draining and Storing the System .....	7
Alarms.....	7
<b>Primary Inspection</b> .....	<b>9</b>
Checklist .....	9
<b>Controller</b> .....	<b>10</b>
Smart Filtration Controller (SFC-55) .....	10
Variable Frequency Controller (VFD).....	10
<b>Priming the System</b> .....	<b>11</b>
Priming Procedure .....	11
<b>Commissioning/Initial Start-Up</b> .....	<b>12</b>
Initial Test Procedures .....	12
<b>Maintenance</b> .....	<b>13</b>
Preventative Maintenance .....	13
Servicing the Water Separators.....	13
Servicing the Primary Filters.....	13
Servicing the Secondary Filters .....	14
Replacement Filter Chart.....	14
<b>Troubleshooting</b> .....	<b>15</b>
<b>AXI International Limited Warranty</b> .....	<b>16</b>
Warranty Claim Procedure.....	17
<b>Technical Assistance and Ordering</b> .....	<b>18</b>
Replacement Filter Elements.....	18
System Identification.....	18

# General Overview

## MTC HC-150 Specifications

Nominal Flow Rate.....	10 - 150 GPM (37.9 - 567.8 LPM)
Primary Filter (Pre-Filter Skid).....	Bag Filter Vessels, Liner Basket for use with 1-800µ Filter Bags
Water Separator (Pre-Filter Skid).....	Dual FP-90 Mechanical Water Separators
Secondary Filter (Pump Skid).....	Cartridge Filter Vessels, 2-30µ Particulate, 10-30µ Water Block, or 3-10µ Micro-glass Filters
Fuel Conditioner (Pump Skid).....	Dual LG-X 4000 Inline Magnetic Conditioner
Plumbing.....	Black Iron
Inlet Ports.....	3" Cam & Groove In
Outlet Ports.....	2.5" Cam & Groove Out
Operating Temperature.....	41 - 104°F (5 - 40°C)
Controller.....	SFC80 Smart Filtration Controller
Electrical.....	480V/60Hz/3Ph
Pump/Motor.....	10 HP Sliding Vane Pump
Suction Capability (Primed).....	15ft. vertical lift or 100ft. horizontal run (lines > 2", primed)
Maximum Fluid Viscosity.....	5 cSt
Clear Suction Hoses.....	3", 25 ft. (7.6m)
Discharge Hose.....	2.5", 25 ft. (7.6m)
Outline Dimensions (Pre-Filter Skid).....	59" x 36" x 45" (150 x 91 x 114 cm) (H x W x D)
Outline Dimensions (Pump Skid).....	59" x 36" x 45" (150 x 91 x 114 cm) (H x W x D)
Weight (Pre-Filter Skid).....	≈ 850 lbs. (385.5 kg)
Weight (Pump Skid).....	≈ 900 lbs. (408.2 kg)

**!WARNING! This system is not meant for use with gasoline or any other flammable liquids having a flash point less than 100°F (37.8° C). Use with gasoline or any flammable liquids at a temperature exceeding their flash point presents an immediate explosion and fire hazard.**

# System Components

## Control and Safety Devices

- SFC80 Smart Filtration Controller
  - Control Circuit Breakers (CB1, CB2)
  - Smart Filtration PLC with LCD Display
  - Pump Control Selector Switch (Manual/Off/Auto)
  - System Power Indicator Light
  - Pump Running Indicator Light
  - Alarm Indicator Light
  - Alarm Reset Push Button
- Vacuum & Pressure Switches
- Vacuum & Pressure Gauges
- Water Detection Alarm Modules
- Inlet and Outlet Butterfly Valves (Pre-Filter Skid)
  - Inlet Isolation Butterfly Valve (Side 1 and 2)
  - Outlet Isolation Butterfly Valve (Side 1 and 2)
- Inlet and Outlet Ball Valves (Pump Skid)
  - Inlet Ball Valve
  - Isolation Ball Valves (Side 1)
  - Isolation Ball Valves (Side 2)
  - Outlet Ball Valve (Discharge Port 1)
  - Outlet Ball Valve (Discharge Port 2)
- Remote Pendant Switch

## Pump/Motor

- 10 HP Sliding Vane Pump
- Internal Pressure Relief

## Primary Filters

- Bag filter element (purchased separately)
- Water Detection Sensor Probe
- Drain Valve

## Mechanical Water Separators

- Water Separator
- Drain Valve

## Fuel Conditioners

- Inline Magnetic Fuel Conditioner

## Secondary Filters

- Cartridge filter element (purchased separately)

## Plumbing

- Black Iron

# System Operation

**!WARNING! The whole system must be properly grounded for operator safety.**

**Note: It is recommended that only qualified, experienced personnel, familiar with this equipment, who have read and understood all the instructions in this manual should operate and maintain the system.**

## Setup Procedures

To establish either fuel polishing mode, the user must attach both system hoses to the system in the proper configuration. The Intake/Suction Hoses are clear and see-through while the Discharge Hose is black and opaque. Both hoses are equipped with quick disconnect cam & groove couplings.

1. First, attach the quick disconnect end of the clear Suction Hose to the Inlet Port of the Pre-Filter Skid.
2. We highly recommend attaching a straight wand or pipe (cut at an angle) to the end of the Suction Hose in order to reach the lowest part of the tank bottom.
3. The straight wand or pipe should be no less than the inner diameter of the Suction Hose.

**Note: Never restrict the flow on the suction side of an MTC; e.g. by using a smaller ID hose or pipe attachment. This will lead to excessive pump load, noisy operation, and ultimately pump damage.**

4. Next, connect one end of the second Suction Hose to the outlet port of the Pre-filter Skid and the other end to the inlet port of Pump Skid.

### **Bypass Mode:**

In bypass mode, the fuel bypasses the Pump Skid's Secondary Filters only to be ran through the Pre-Filter Skid's Primary Filters and Water Separators for the bulk removal of water, sludge, and particulate. To establish bypass mode:

1. Attached the quick disconnect end of the black Discharge Hose to Discharge Port 1 of the Pump Skid (located just above the Pump Skid's Inlet Port).
2. Before running the pump, ensure all Inlet, Outlet, and Isolation Butterfly Valves on the Pre-Filter Skid, the Pump Skid's Inlet Ball Valve, and the proper Discharge Ball Valve (Discharge Port 1) are in the open position.
3. Also, ensure the other discharge ball valve (Discharge Port 2), all Pump Skid Isolation Ball Valves (Side 1 and 2), and the Water Separator and Primary Filter drain valves are in the closed position.

### **Fine Filtration Mode:**

In fine filtration mode, the fuel is run through the Pump Skid's high efficiency Secondary Filter elements to remove free water and fine particulate as small as 1 micron. To establish fine filtration mode:

1. Attached the quick disconnect end of the black Discharge Hose to Discharge Port 2 (located after the Secondary Filter Vessels).
2. Before running the pump, ensure all Inlet, Outlet, and Isolation Butterfly Valves on the Pre-Filter Skid, the Pump Skid's Inlet and Isolation Ball Valves (Side 1 and 2), and the proper Discharge Ball Valve (Discharge Port 2) are in the open position.
3. Also, ensure the other Discharge Ball Valve (Discharge Port 1), and the Water Separator and Primary Filter drain valves are in the closed position.

## Pump Operation

To startup the system, you must first apply control power to unit. Place the control breakers for the System Controller in the "ON" position.

### Remote Mode:

Place the Selector Switch in the “AUTO” position. To activate the pump simply press the Remote Pendant Switch. The pump will now run until either the Remote Pendant Switch is pressed again, the Selector Switch is placed in the “OFF” position, or a system alarm has been tripped.

### Manual Mode:

Place the Selector Switch in the “MANUAL” position. The pump will now run until either the Select Switch is placed in the “OFF” position or a system alarm has been tripped.

**Note:** See the Controller – Variable Frequency Controller (VFD) section for information on adjusting the system’s flow rate with the VFD Controller.

## Phase 1

AXI recommends 3 phases to successfully polish a fuel tank. This will ensure all contaminants are removed and the fuel is in optimal condition.

The goal of Phase One is to remove any free water and sludge from the bottom of the tank without mixing the water into an emulsified state within the fuel. The Pump will start pumping as long as the system is primed (See Priming the System section) and the suction lift is not excessive. The flow of the fuel can be observed in the see-through suction hose. Watch for a steady flow of fuel into the container.

1. Setup up the system in the Bypass Mode configuration (see Setup Procedures – Bypass Mode) and be sure to install a large micron (200 $\mu$  or larger) filter bags in the Primary Filter vessels on Pre-Filter Skid.

**Note:** Primary filters should always have some type of primary filter bag in place during operation to extend life of the pump vanes.

2. Place the Discharge Hose into a separate discharge waste container and ensure that the hose is secured and will not vibrate out of the container when the system is operating.
3. To remove as much of the free water and sludge as possible, the Suction Hose (with a straight wand or pipe attachment) should be placed at the deepest part of the tank.
4. Connect the system to an appropriate power source and switch the breakers on the System Controller to “ON”. The “System Power” Indicator should illuminate on the System Controller.
5. Set the Pump to run at a lower initial speed (10-20 Hz) by adjusting the knob on the VFD Controller and turn the Pump on via the Selector Switch on the System Controller.
6. Be prepared to immediately switch the pump off once the fluid begins to fill the discharge container in order to inspect the discharge fluid.
7. Resume pumping until the bulk water and sludge have been removed from the tank bottom and only fuel is primarily discharged from the return hose.
8. Switch off the Pump and drain all water and debris from the hose and the Water Separator (via the drain valves) into an appropriate waste bucket or container.

## Phase 2

The goal of Phase Two is to remove any additional free water, sludge, and large contaminants within the tank. This phase will further clean the fuel and should be a precursor to using the more expensive fine filters. It should be noted that meeting required cleanliness codes is typically not possible with Phase One and Two alone. Phase Two is simply used to extend the life of the Secondary Filter’s fine filter cartridges by removing the worst of the contaminants first.

1. Before turning on the Pump, ensure the system is still setup in the Bypass Mode configuration (see Setup Procedures – Bypass Mode).
2. Remove the Discharge Hose from the waste container and place it into the tank.
3. If possible, ensure the Suction and Discharge Hoses are placed as far apart as possible.

**Note:** In many cases, both hoses may have to be inserted through the same tank opening.

4. After verifying that both hoses are properly placed in the fuel tank and that the ball valves on the system are in the correct position, switch on the pump and watch the clear suction hoses for fuel flow.
5. While polishing, it is good practice to watch the fuel flow and regularly stop the pump to check for buildup of free water and sludge in the Water Separators (see Maintenance – Servicing the Water Separator). Should the water level rise and trip a Water Sensor Probe on one of the Water Separators, a High Water alarm will be triggered indicating that the Water Separator needs to be drained of water.
6. It is also good practice to monitor the Vacuum Gauges for both Side 1 and Side 2 of the Pre-Filter Skid to know when to service a clogged Primary Filter element in order to avoid flow restriction (see Maintenance – Servicing the Primary Filter). Should a Vacuum Switch detect a reading above the pre-established set point, a High Vacuum alarm will be triggered indicating that the corresponding Primary Filter bag needs to be changed.
7. The system should be kept running until clean fuel samples can be drained from the Water Separator. Once this is achieved, switch off the pump to prepare for the final polishing phase.

## Phase 3

Phase Three is the most important phase in meeting specific cleanliness codes. Unlike the Primary Filter and Water Separator, the Secondary Filter's fine filter cartridges typically uses an absolute rated media. Absolute filters have a very high efficiency and will ensure that fuel leaving the system is clean to specification.

1. Before turning on the Pump, ensure the system is setup in the Fine Filtration Mode configuration (see Setup Procedures – Fine Filtration Mode) and be sure to install filter bags and cartridges in all Primary and Secondary Filter Vessels respectively.
2. After verifying that both hoses are properly placed in the fuel tank and that the ball valves on the system are in the correct position, start the pump and monitor the Pressure Gauges in addition to the Vacuum Gauges to also know when the Secondary Filters need servicing (see Maintenance – Servicing the Secondary Filter). Should the Pressure Switches detect a reading above the pre-established set point, a High Pressure alarm will be triggered indicating that the Secondary Filter cartridge needs to be changed.

## Draining and Storing the System

1. Set pump motor to operate at a low speed (10-15 Hz).
2. Remove the suction hose from the tank while the pump is still running and wait until system is purged of any remaining fuel as indicated by an audible change in the pump's operation.

**!WARNING! DO NOT operate the vane pump dry for longer than 60 seconds to avoid significant mechanical damage.**

3. Turn off the pump and place an appropriate container under the Water Separators and Discharge Port 1.
4. Open their respective ball valve and use the air purge valve on top of the separators to make sure all of the fluid can be drained from the system.

## Alarms

**Alarms featured on the system include:**

- High Water (pump shutdown, alarm indication)
  - Activated when the water trips the Water Detection Alarm Module via the Water Detection Sensor Probe located on the Mechanical Water Separator. The system will go into an alarm state and the pump will not be allowed to run until the Water Separator has been serviced (see Maintenance – Servicing the Water Separator) and the alarm has been cleared via the Alarm Reset Button on the system controller.
- High Vacuum (pump shutdown, alarm indication)

- 
- Activated when the Vacuum Switch, placed on the suction side of the pump, detects a reading above the pre-established set point. The system will go into an alarm state and the pump will not be allowed to run until the Primary Filter has been serviced (see Maintenance – Servicing the Primary Filter) and the alarm has been cleared via the Alarm Reset Button on the system controller.
  - High Pressure (pump shutdown, alarm indication)
    - Activated when the Pressure Switch, placed on the discharge side of the pump, detects a reading above the pre-established set point. The system will go into an alarm state and the pump will not be allowed to run until the Secondary Filters have been serviced (see Maintenance – Servicing the Secondary Filters) and the alarm has been cleared via the Alarm Reset Button on the system controller.



## Primary Inspection

Upon arrival, the system and accessories must be visually inspected before installation. Improper handling during shipping may cause physical or electrical problems. Immediately report or note any damages (also concealed ones) to the shipper.

### Checklist

- Check the entire system for damage that could indicate internal mechanical or electrical problems.
- Check pump/motor hardware and all plumbing connections for tightness.
- Check all electrical terminals and connections for tightness.

# Controller

## Smart Filtration Controller (SFC-55)

The System Controller is used to both operate the system and indicate/reset system alarms should they be triggered.

### Pump Control Selector Switch (Manual/Off/Auto)

Turns the system on to either “Manual” or “Remote” operational modes (See Operation – System Controller)

### Pump Running Indicator Light

Indicated the system pump is running

### System Power Indicator Light

Indicates the system has power

### Alarm Indicator Light

Indicates the labeled alarm (displayed on the Smart Filtration PLC) has been tripped

### Alarm Reset Push Button

Resets the system alarm(s) once the alarm state(s) have been addressed

## Variable Frequency Controller (VFD)

In normal operation the Variable Frequency Controller is used ONLY to change the speed of the pump. When the Smart Filtration Controller is set to run the pump will turn on and accelerate to the set VFD speed.

### Output Frequency

The MTC HC-150 system has a Sliding Vane Pump that operates at 150 GPM when connected to a 480 VAC/60 Hz circuit. Manipulating the VFD to the following ratio can yield a range of desired flow rates.

*Flow Rate as a function of Frequency:*

$$\text{Flow Rate (GPM)} = 2.5 \times \text{Frequency (Hz)}$$

$$\text{Example: } 25 \text{ (GPM)} = 2.5 \times 10 \text{ (Hz)}$$

### Frequency Knob

Toggles the pump speed between 10 Hz to 60 Hz

**Note: All other VFD Control Functions are disabled.**



## Priming the System

The pump supplied with the system is NOT automatically self-priming and must not be run dry.

**!WARNING! If the pump is allowed to run without fuel, pump damage can occur.**

### Priming Procedure

Before turning on the pump make sure the entire suction side of the system (suction hose, primary filter/water separator, plumbing, and pump) is primed and filled with oil/diesel fuel. Running the pump dry could cause pump damage and pump to not operate properly.



# Commissioning/Initial Start-Up

## Initial Test Procedures

With breakers and power turned on, and pump running, check all alarms for proper operation:

- **High Water Alarm** - Jump the Water Detection Sensor Probes by placing a conductor across the two horizontal contacts. The pump should turn off after 10 seconds and “High Water” alarm should be indicated on the System Controller. Remove the metal and reset the alarm by pushing the Alarm Reset button on the System Controller.
- **High Vacuum Alarm** - Slowly, partially close Inlet Butterfly Valve on Pre-Filter Skid. At 16” HG, the pump should turn off and the “High Vacuum” alarm should be indicated on the System Controller. Open the Inlet Butterfly Valve again. Reset the alarm by pushing the Alarm Reset button on the System Controller.
- **High Pressure Alarm** - Slowly, partially the Outlet Ball Valve on the Pump Skid. At 22 PSI, the pump should turn off (after a delay of about 1 second) and the “High Pressure” alarm should be indicated on the System Controller. Open the Outlet Ball Valve again. Reset the alarm by pushing the Alarm Reset button on the System Controller.

**Note:** If any of the above described alarm test procedures fail or if any alarm trip value deviates, immediately contact AXI International.

### Testing the VFD:

While the pump is running, incrementally toggle the VFD speeds from 10Hz to 60Hz via the Variable Frequency to ensure proper functionality of the VFD and system pump/motor assembly.

# Maintenance

The system should be visually inspected and tested a minimum of every six (6) months according to the procedure below during light duty cycles. Monthly inspections are recommended for systems that are being used in excess of an average of eight (8) hours a day and five (5) days a week.

## Preventative Maintenance

Prior to performing the maintenance procedure ensure that:

1. All sources of power are isolated from the unit

**Note: Proceed only after this has been verified and properly tagged.**

2. Check system and all parts for corrosion and rust.
3. Check bolts on the pump/motor hardware for tightness, as pump/motor hardware can loosen after normal operation for extended durations of time, due to vibration.
4. Check all plumbing joints for leaks, tighten fittings and joints as necessary.
5. Inspect all filter vessels and elements.

## Servicing the Water Separators

It is recommended the Water Separators be periodically serviced to prevent excessive water buildup. A “High Water” alarm will indicate when the water separators need to be drained.

**Draining of Water Separator:**

1. Ensure the system’s pump is turned off.
2. Close the inlet butterfly and outlet ball valves.
3. Place an appropriate container under the Water Separator’s drain valve.
4. Remove the top plug to allow air in and fuel to flow out.
5. Open the drain valve and allow the water and sludge to drain.
6. Close the drain valve when you begin observing clean fuel.

**Note: Disposal of fuel, associated waste, and filters must be in accordance with all applicable federal, state, and local rules, laws, standards, and regulations.**

**!WARNING!: Some fuels may have been treated with biocides. Biocides are extremely toxic and may enter the body through the skin. It is recommended to use adequate protection and proper precautions if the fuel at-hand contains biocide type products.**

## Servicing the Primary Filters

A clogged filter element restricts the flow of fuel, resulting in the vacuum gauges indicating a pressure drop. A “High Vacuum” alarm will indicate when a filter change should be made on the Primary Filters.

**Changing a Bag Filter:**

1. Ensure the system’s pump is turned off.
2. Close the inlet butterfly and outlet ball valves.
3. Release all pressure in system by carefully opening the air vent valves.
4. Loosen the vessel’s lid screws and open the lid
5. Remove the old filter bag and check the inner housing for any debris or sludge.
6. Place the new filter bag into the housing.
7. Apply a film of lubricating oil to the lid gasket. Replace the O-Ring if worn or damaged.
8. Tighten the lid screws evenly to ensure the lid is fully seated on the O-Ring gasket.
9. Open the inlet butterfly and outlet ball valves.

10. Check for leaks when re-starting and pressurizing the system.

## Servicing the Secondary Filters

A clogged filter element restricts the flow of fuel, resulting in the system's pressure gauges indicating a pressure spike. A "High Pressure" alarm will indicate when a filter change should be made on the Secondary Filters.

### Changing a Fine Filter Cartridge:

1. Ensure the system's pump is turned off.
2. Close the inlet butterfly and outlet ball valves.
3. Release all pressure in system by carefully opening the air vent valves.
4. Loosen the vessel's lid screws and open the lid
5. Remove the old filter cartridge(s) and check the inner housing for any debris or sludge.
6. Place the new filter element into the housing.
7. Apply a film of lubricating oil to the lid gasket. Replace the O-Ring if worn or damaged.
8. Tighten the lid screws evenly to ensure the lid is fully seated on the O-Ring gasket.
9. Open the inlet butterfly and outlet ball valves.
10. Check for leaks when re-starting and pressurizing the system.

## Replacement Filter Chart

### MTC HC SERIES FILTERS

ALL FILTERS ARE ABSOLUTE, UNLESS OTHERWISE NOTED | WB: WATERBLOCK | SS: STAINLESS STEEL SCREEN

CARTRIDGE FILTERS								
	2 $\mu$	10 $\mu$	10 $\mu$ WB	30 $\mu$	30 $\mu$ WB	3 $\mu$ MICRO-GLASS	7 $\mu$ MICRO-GLASS	10 $\mu$ MICRO-GLASS
MTC HC-50	618-2-W	618-10-W	WA618-30-W	618-30-W	WA618-30-W	G618-3-SR	G618-7-SR	G618-10-SR
MTC HC-90	618-2-W	618-10-W	WA618-30-W	618-30-W	WA618-30-W	G618-3-SR	G618-7-SR	G618-10-SR
MTC HC-150	618-2-W	618-10-W	WA618-30-W	618-30-W	WA618-30-W	G618-3-SR	G618-7-SR	G618-10-SR
MTC HC-300	618-2-W	618-10-W	WA618-30-W	618-30-W	WA618-30-W	G618-3-SR	G618-7-SR	G618-10-SR

BAG FILTERS							
	1 $\mu$	5 $\mu$	10 $\mu$	25 $\mu$	75 $\mu$	250 $\mu$	800 $\mu$
MTC HC-50	PFB-30-1	PFB-30-5	PFB-30-10	PFB-30-25	PFB-30-75	PFB-30-250	PFB-30-800
MTC HC-90	PFB-30-1	PFB-30-5	PFB-30-10	PFB-30-25	PFB-30-75	PFB-30-250	PFB-30-800
MTC HC-150	PFB-150-1	PFB-150-5	PFB-150-10	PFB-150-25	PFB-150-75	PFB-150-250	PFB-150-800
MTC HC-300	PFB-150-1	PFB-150-5	PFB-150-10	PFB-150-25	PFB-150-75	PFB-150-250	PFB-150-800

# Troubleshooting

## No fuel delivery

1. Pump does not run
2. Pump is not primed
3. Fuel supply line blocked
4. Excessive lift
5. Air leak in fuel supply to pump
6. Pump rotation direction incorrect
7. Intake or outlet valve closed
8. Check valve installed backwards

## Insufficient fuel delivered

1. Air leak at inlet
2. Defective pressure relief valve or check valve
3. Excessive lift
4. Pump worn
5. Inoperative foot valve
6. Piping improperly installed or dimensioned
7. Primary filter/water separator plugged

## Rapid pump wear

1. Pipe strain on pump causing bind
2. Worn pump/motor coupler
3. Pump has been run dry or with insufficient fuel
4. Plumbing on inlet side not appropriately dimensioned

## Alarm “HIGH VACUUM ALARM” comes on with clean or new filter element installed

1. Heavily contaminated fuel/excessive water in tank
2. Restriction in plumbing on inlet side too high
3. Excessive lift
4. Inoperative foot valve
5. Inlet ball valve not fully open
6. Suction line clogged

## Alarm “HIGH PRESSURE ALARM” comes on with clean or new filter element installed

1. Heavily contaminated fuel/excessive water in tank
2. Restriction in plumbing on discharge side too high
3. Head (lift) on discharge side too high
4. Check valve stuck or defective
5. Outlet ball valve not fully open
6. Discharge line clogged

## Pump requires too much power

1. Air in plumbing lines
2. Liquid too viscous
3. Bent pump shaft, binding rotor
4. Misalignment of pump/motor coupler

## Noisy operation

1. Insufficient fuel supply
2. Air leaks in the inlet pipe
3. Air or gas in fuel on the suction side
4. Excessive pump load (vacuum > 15” HG)

## Pump requires frequent re-priming

1. Inoperative foot valve
2. Inoperative check valve
3. Inoperative solenoid valve
4. Pump cavitation
5. Plumbing air leaks
6. Lift too high
7. Leaking pump seal

## Motor does not turn or turns intermittently

1. Control power not available
2. Motor thermal overload condition
3. Pump failed and seized
4. Motor failure

## Pump leaks fuel

1. Loose pump plumbing fittings
2. Worn pump shaft seal
3. Pump pressure relief valve failure
4. Fuel leak elsewhere and fuel dripping or running towards the pump
5. Excessive head from overhead storage tank
6. Worn pump O-rings or seals

# AXI International Limited Warranty

AXI International makes every effort to assure that its products meet high quality and durability standards and expressly warrants the products described herein against defects in material and workmanship for a period of one (1) year from the date of purchase. This warranty is not intended to supplant normal inspection, care and service of the products covered by the user, and shall not obligate AXI International to provide free service during the warranty period to correct breakage, maladjustment, or other difficulties arising out of abuse, misuse, or improper care and maintenance of such products. Our express warranty is subject to the following terms and conditions:

This warranty shall only extend to and is only for the benefit of original purchaser(s), or end customer(s) who use the products covered hereby and subject to the terms and conditions herein. This warranty is not an on-site warranty. Travel requests will be at the discretion of AXI International. Defective systems and ancillary products will require a return authorization number and shipping to AXI International's factory in Fort Myers, FL. Any warranty claim received by AXI International after one (1) year from the date of purchase will not be honored even if it is claimed that the defect occurred prior to one (1) year from the date of purchase. Claims outside of this one (1) year period, and for claims not listed within, payment, repair, or service will be awarded at the sole and exclusive discretion of AXI International.

## **This Warranty shall NOT apply to the following:**

1. Damage or deterioration caused by normal wear and tear.
2. Failures caused by any external cause or act of God, such as accident, collision, theft, vandalism, riots, wars, re, freezing, lightning, earthquakes, windstorms, hail, volcanic eruptions, floods, tornados or hurricanes.
3. Failures due to alterations, adjustments, unauthorized changes to the product(s), neglect or improper storage, repair and/or maintenance.
4. Failures due to abuse or application of the product(s) for uses other than for which it/they are designed or intended by AXI International, including but not limited to, improper installation or location in a harsh, corrosive or saltwater environment.
5. Failures resulting from attachments, accessory items, and parts not sold by AXI International.
6. Repairs by any party other than those authorized by AXI International.
7. Failures resulting from user's delay in making the product available for inspection by AXI International after notifying AXI International of a potential product problem.
8. Cosmetic damage, discoloration, rusting, corrosion or scratches from applied paint.
9. Replacement of consumables such as, but not limited to, fuses, lamps, filters, etc.
10. Additional expenses for repair after normal business hours, i.e., overtime or holiday labor rates.
11. Expenses for rental of equipment during downtime and/or performance of warranty repairs.
12. Expenses related to investigating performance complaints and/or troubleshooting where no manufacturing defect is found.

In addition to the limitations above, this warranty shall not apply to products (1) which have been tampered with, altered or repaired by anyone other than AXI International without the express prior written consent of AXI International (2) which have been installed improperly or subject to misuse, abuse, accident, negligence of others, improper operation or maintenance, neglect or modification, or (3) which have had the serial number altered, defaced or removed.

The liability of AXI International under this warranty is limited to the repair or replacement of the defective product. AXI International assumes NO LIABILITY for labor charges or other costs incurred by any purchaser incidental to the service, adjustment, repair, return, removal or replacement of products. AXI INTERNATIONAL ASSUMES NO LIABILITY FOR ANY GENERAL, SPECIAL, INCIDENTAL, CONSEQUENTIAL, CONTINGENT OR OTHER DAMAGES UNDER ANY WARRANTY, EXPRESS OR IMPLIED, OF MERCHANTABILITY, FITNESS FOR A PARTICULAR PURPOSE OR OTHERWISE, WITH THE RESPECT TO THE PRODUCTS COVERED BY THIS WARRANTY POLICY, EXCEPT AS EXPRESSLY PROVIDED FOR HEREIN. AXI INTERNATIONAL ASSUMES NO LIABILITY FOR ANY GENERAL, SPECIAL, INCIDENTAL, CONSEQUENTIAL, CONTINGENT OR OTHER DAMAGES EVEN IF SUCH DAMAGES ARE A DIRECT RESULT OF AXI INTERNATIONAL'S NEGLIGENCE. NO EMPLOYEE, AGENT, REPRESENTATIVE OR DISTRIBUTOR IS AUTHORIZED TO MAKE ANY WARRANTY ON BEHALF OF AXI INTERNATIONAL OTHER THAN THE EXPRESS WARRANTY PROVIDED FOR HEREIN.



AXI International reserves the right at any time to make changes in the design, material, function and specifications of its products. Any such changes shall not obligate AXI International to make similar changes in such products that were previously manufactured.

To the fullest extent permitted by law, any claims against AXI International are limited to the remedies as expressly set forth in this warranty and any other further claims, such as but not limited to, compensation for any damage incurred other than to the AXI International product, are hereby excluded.

## Warranty Claim Procedure

To make a claim under this warranty, please call AXI International at +1-239-690-9589 or 1-877-425-4239, and provide: Name and location where unit was purchased, the date and receipt of purchase, model number, serial number, and a detailed explanation of the problem you are experiencing. The Customer Service Representative may, at the discretion of AXI International, arrange for a Field Engineer to inspect your system. If the inspection reveals a defect covered by its limited warranty, AXI International will either repair or replace the defective parts or products. AXI International assumes no liability, if upon inspection, AXI International or its representative determines that there is no defect or that the damage to the system resulted from causes not within the scope of this limited warranty and customer shall be responsible standard rates incurred by AXI International, as established from time to time by AXI International.

For service and sales, please contact AXI International:

AXI International | 5400 Division Drive Fort Myers, FL 33905  
Tel: +1-239-690-9589 | Toll Free: +1-877-425-4239 | Fax: +1-239-690-1195  
Email: [info@axi-international.com](mailto:info@axi-international.com) | Internet: [www.axi-international.com](http://www.axi-international.com)



# Technical Assistance and Ordering

Please write, fax, email or call:

AXI International  
5400 Division Drive  
Fort Myers, FL 33905  
Tel: +1-239-690-9589  
Fax: +1-239-690-1195  
Email: info@axi-international.com Internet: www.axi-international.com

## Please provide the following information:

Serial Number of your system, the required part numbers and quantity. The drawings/parts list included in this manual are the most accurate source of part numbers.

## Replacement Filter Elements

### Primary Filter:

PFB-150-1 - 1 $\mu$  Bag Filter  
PFB-150-5 - 5 $\mu$  Bag Filter  
PFB-150-10 - 10 $\mu$  Bag Filter  
PFB-150-25 - 25 $\mu$  Bag Filter  
PFB-150-75 - 75 $\mu$  Bag Filter  
PFB-150-250 - 250 $\mu$  Bag Filter  
PFB-150-800 - 800 $\mu$  Bag Filter

### Secondary Filters:

618-2-W - 2 $\mu$  Filter Cartridge  
618-10-W - 10 $\mu$  Filter Cartridge  
618-30-W - 30 $\mu$  Filter Cartridge  
WA618-10-W - 10 $\mu$  Filter Cartridge (Water Block)  
WA618-30-W - 30 $\mu$  Filter Cartridge (Water Block)  
G618-3-SR - 3 $\mu$  Microglass Absolute Filter Cartridge  
G618-7-SR - 7 $\mu$  Microglass Absolute Filter Cartridge  
G618-10-SR - 10 $\mu$  Microglass Absolute Filter Cartridge

## System Identification

**Serial Number:** \_\_\_\_\_ (e.g. B090010-HC-150)

**Inspected By:** \_\_\_\_\_ **Date:** \_\_\_\_\_